



Infinitely many arithmetic alternating links: Class number greater than one

M. D. Baker 

*IRMAR, Université de Rennes,
35042 Rennes Cedex, France
mark.baker@univ-rennes.fr*

A. W. Reid 

*Department of Mathematics,
Rice University, Houston, TX 77005, USA
alan.reid@rice.edu*

Received 25 May 2023
Accepted 23 October 2023
Published 29 January 2024

ABSTRACT

We prove the existence of infinitely many alternating links in S^3 whose complements are commensurable with the Bianchi orbifold $\mathbb{H}^3/\mathrm{PSL}(2, O_{15})$.

Keywords: Alternating link; arithmetic link complement.

Mathematics Subject Classification 2020: 57K32, 11F06

1. Introduction

Alternating links and their complements in S^3 have long held a fascination for knot theorists and low-dimensional topologists. Following Thurston's seminal work, an attractive theme emerged: to relate the geometry and topology of the complement of an alternating link in S^3 to combinatorics of an alternating diagram. For example, in [24] if L is a non-split prime alternating link which is not a torus link, then $S^3 \setminus L$ has a complete hyperbolic structure of finite volume. Moreover, in [23], Menasco describes a method whereby the hyperbolic structure is built explicitly from a polyhedral decomposition of the complement using the combinatorics of an alternating diagram. Menasco's work shows many alternating links have hyperbolic complements, and in this paper, we continue our investigation into how common it is for alternating links in S^3 to have *arithmetic complements*, the definition of which we now briefly recall.

*Corresponding author.

Let d be a square-free positive integer and let O_d denote the ring of integers of $\mathbb{Q}(\sqrt{-d})$. A non-compact finite volume hyperbolic 3-manifold X is called *arithmetic* if X and the Bianchi orbifold $Q_d = \mathbb{H}^3/\mathrm{PSL}(2, O_d)$ are commensurable, that is to say they share a common finite sheeted cover (see [22, Chaps. 8 and 9] for further details). If $X = S^3 \setminus L$, we call L an *arithmetic link*.

Going back to Thurston’s Notes [31], many arithmetic link complements have been constructed; for a selection see [1, 3–8, 14, 15, 17, 18]. Of most relevance to the focus of this note is [18], where examples of alternating link complements covering Q_d were constructed in the cases $d \in \{1, 2, 3, 7, 11\}$ (building on the ideas in [31]). More recently, in [9], we constructed two *infinite families of alternating links* whose complements are non-homeomorphic and cover Q_3 (thereby answering a question of Lackenby [21] and independently Futer).

Now it is known by [6] that for every d arising in the solution of the Cuspidal Cohomology Problem (see [32]); i.e. for those d in

$$C = \{1, 2, 3, 5, 6, 7, 11, 15, 19, 23, 31, 39, 47, 71\},$$

link complements covering Q_d exist (see [8] for many explicit diagrams). However, as far as the authors are aware, no example of an arithmetic alternating link complement covering Q_d is known outside of $d \in \{1, 2, 3, 7, 11\}$. We do note that the 6-circle alternating chain link C_6 was proven to have complement admitting a complete hyperbolic structure of finite volume by Thurston [31, Chap. 6.33–6.37], and arithmeticity of C_6 was established in [25] where it was shown that $S^3 \setminus C_6$ is commensurable with Q_{15} , but it was not checked whether $S^3 \setminus C_6$ covered Q_{15} . We address this point in Remark 3.5, and also for the links constructed in this paper (see Sec. 2.2, and in particular Remarks 3.5 and 3.6).

In the context of the previous paragraph, the key additional complexity in determining whether a link complement covers Q_{15} or not is that $\mathbb{Q}(\sqrt{-15})$ has class number 2. In the case where the class number h_d of $\mathbb{Q}(\sqrt{-d})$ is even, the structure of maximal orders of $M(2, \mathbb{Q}(\sqrt{-d}))$ yields other possible groups of units of maximal orders whose images in $\mathrm{PSL}(2, \mathbb{C})$ are commensurable with (but not conjugate to) $\mathrm{PSL}(2, O_d)$ and for which link groups can arise as subgroups of finite index. As well as the list of $d \in C$ with h_d even, the cases of $d \in C' = \{10, 14, 35, 55, 95, 119\}$ are also possible [10], and it is known that for some of these other unit groups, link groups arise as subgroups of finite index; see for example [7, 28, 29].

The main result of this note is the following. We refer to Sec. 2 for the definition of the group $\Gamma_{\mathcal{O}}^1$.

Theorem 1.1. *There are two infinite families of arithmetic alternating links in S^3 whose complements cover the orbifold $\mathbb{H}^3/\Gamma_{\mathcal{O}}^1$ which is commensurable with Q_{15} .*

The two families of links will be denoted by D_j and \mathcal{D}_j ($j \geq 1$), respectively. The link D_j consists of $(j + 1)$ concentric circles centered at the origin in the Euclidean plane, with three additional circles linking them (D_2 is shown in Fig. 1(a)). The link

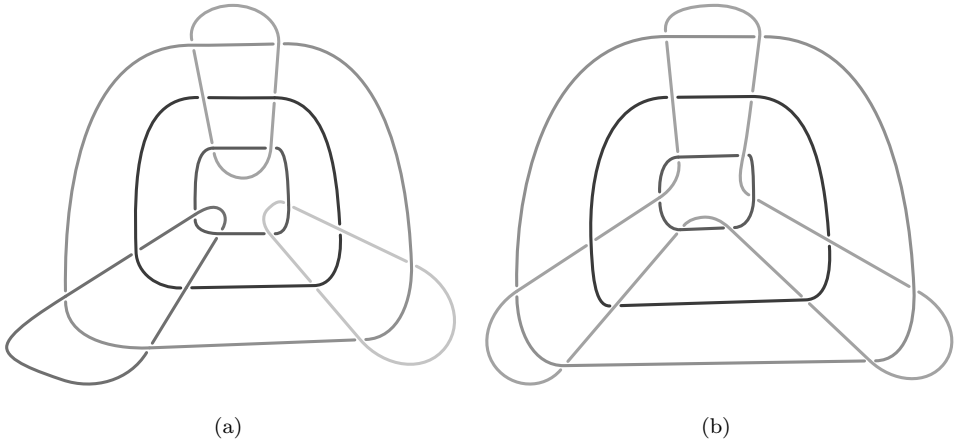

Fig. 1.

\mathcal{D}_j also consists of $(j + 1)$ concentric circles centered at the origin in the Euclidean plane, but in this case, with only one additional circle added (\mathcal{D}_2 is shown in Fig. 1(b)).

The method of proof follows the ideas of [9] where two infinite families of alternating links were proved to be arithmetic by decomposing their complements into regular ideal hyperbolic cubes, and observing that manifolds admitting such a decomposition (i.e. cubical manifolds) are arithmetic. To prove Theorem 1.1, the basic building block used is a certain ideal hyperbolic hexagonal prism (that we describe in Sec. 3.1): this was first used by Thurston [31] in his proof that $S^3 \setminus C_6$ admits a complete hyperbolic structure of finite volume. However, things are more complicated than the cubical case, since there also exist *non-arithmetic* alternating link complements built from the ideal hyperbolic hexagonal prism described in Sec. 3.1 (see Sec. 4.1).

2. The Commensurability Class of Q_{15}

In the proof of Theorem 1.1, we will need information about certain groups and orbifolds in the commensurability class of $\text{PSL}(2, O_{15})$ and Q_{15} .

2.1. Arithmetic link complements commensurable with Q_{15}

Recall that $\mathbb{Q}(\sqrt{-15})$ has class number 2, and a representative of the non-trivial ideal class is given by an ideal of norm 2, namely $I = \langle 2, 1 + \frac{(1 + \sqrt{-15})}{2} \rangle$. It is known (see [22, Chap. 2.2, Example 6.7.9]) that every maximal order in $M(2, \mathbb{Q}(\sqrt{-15}))$ is $\text{GL}(2, \mathbb{Q}(\sqrt{-15}))$ -conjugate to either $M(2, O_{15})$ or the order

$$\mathcal{O} = \left\{ \begin{pmatrix} a & b \\ c & d \end{pmatrix} \in M(2, \mathbb{Q}(\sqrt{-15})) : a, d \in O_{15}, c \in I, b \in I^{-1} \right\}.$$

Let $\Gamma_{\mathcal{O}}^1$ denote the image in $\text{PSL}(2, \mathbb{C})$ of the elements of determinant one in \mathcal{O} . Using this description, and the fact that any link group is generated by meridians of the link (and hence parabolic elements if the link complement is hyperbolic) we deduce the following corollary from [22, Theorem 9.2.2].

Corollary 2.1. *Let $L \subset S^3$ be a link so that $S^3 \setminus L = \mathbb{H}^3/\Gamma$ is commensurable with Q_{15} . Then Γ is conjugate into $\text{PSL}(2, O_{15})$ or $\Gamma_{\mathcal{O}}^1$ (or possibly both).*

2.2. Minimal orbifolds

As discussed in [22, Chap. 11.1.3], the orbifolds Q_{15} and $\mathbb{H}^3/\Gamma_{\mathcal{O}}^1$ have the same volume (approximately 3.1386138944646...), and the maximal Kleinian groups in the commensurability class of $\text{PSL}(2, O_{15})$ in $\text{PSL}(2, \mathbb{C})$ that contain $\text{PSL}(2, O_{15})$ (respectively, $\Gamma_{\mathcal{O}}^1$) contain $\text{PSL}(2, O_{15})$ (respectively, $\Gamma_{\mathcal{O}}^1$) as normal subgroups of index 4, both with $\mathbb{Z}/2\mathbb{Z} \times \mathbb{Z}/2\mathbb{Z}$ quotients (see [22, Chap. 11.5.1]). Let $\Gamma_{\mathcal{O}}$ denote the maximal Kleinian group in $\text{PSL}(2, \mathbb{C})$ containing $\Gamma_{\mathcal{O}}^1$. Hence, the volume of the minimal orientable orbifold $Q_{\mathcal{O}} = \mathbb{H}^3/\Gamma_{\mathcal{O}}$ is approximately 0.7846534736.... We now give a description of the orbifold $Q_{\mathcal{O}}$.

Lemma 2.2. *The orbifold $Q_{\mathcal{O}}$ has underlying space the 3-ball with singular locus as shown in Fig. 2(a).*

Proof. Throughout the proof, an integer n associated to an arc or circle of the singular locus indicates a cone angle of $2\pi/n$ at that arc or circle. For the proof we will denote the orbifold shown in Fig. 2(a) by \mathcal{B} .

Note that the singular set in Fig. 2(a) can be isotoped to that shown in Fig. 2(b).

Take the 2-fold cover $\mathcal{B}' \rightarrow \mathcal{B}$ branched over the circle of cone angle π indicated by \leftarrow in Fig. 2(b). This produces the orbifold shown in Fig. 3.

A further 2-fold cover $\mathcal{B}'' \rightarrow \mathcal{B}'$ branched over the circle of cone angle π indicated by \rightarrow in Fig. 3, produces the orbifold shown in Fig. 4.

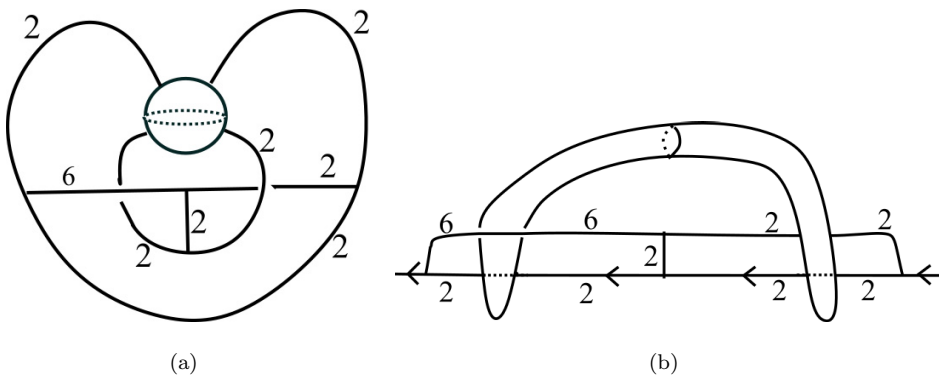

Fig. 2.

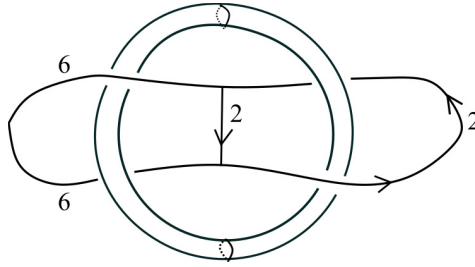

Fig. 3.

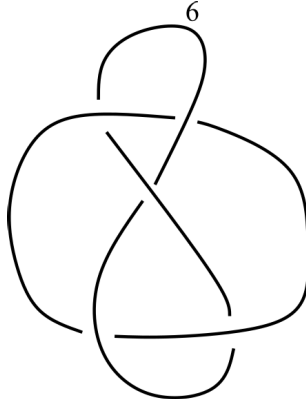

Fig. 4.

This orbifold, denoted by $Y = \mathbb{H}^3/\Gamma_6$, is that obtained by $(6, 0)$ Dehn filling on one component of the Whitehead link, which was proved to be arithmetic in [25] and commensurable with Q_{15} . Thus, \mathcal{B} is (hyperbolic and) arithmetic, commensurable with Q_{15} .

To complete the proof, we must show that the orbifold \mathcal{B} is isometric to $Q_{\mathcal{O}}$. To that end, we first observe that our calculations above show that $\text{Vol}(\mathcal{B}) = \text{Vol}(Y)/4$. Using SnapPy [12], the volume of Y is approximately $3.1386138944646\dots$ (i.e. the volume of Q_{15}), and so $\text{Vol}(\mathcal{B}) = 0.7846534736\dots$. Using the possibilities for volumes of minimal orbifolds (see [22, Chap. 11]), the only possibilities for \mathcal{B} are $Q_{\mathcal{O}}$ or \mathbb{H}^3/G_{15} where G_{15} is the maximal Kleinian group containing $\text{PSL}(2, O_{15})$. We claim that the latter is not possible. To see this, we use [19] and argue as follows.

From [19], we obtain a description of the orbifold $\mathbb{H}^3/\text{PGL}(2, O_{15})$, and as Hatcher notes in [19], because 15 is divisible by two primes, there is a π -rotation that is visible in the diagram in [19]. Taking the quotient of $\mathbb{H}^3/\text{PGL}(2, O_{15})$ by this rotation does not create 6-torsion; i.e. $\mathcal{B} \neq \mathbb{H}^3/G_{15}$ as required. \square

3. The Hexagonal Prism and Arithmeticity of the Links D_j and \mathcal{D}_j

3.1. The hexagonal prism

Let \mathcal{P} denote the convex ideal hyperbolic hexagonal prism of [31, Chap. 6] shown in Fig. 5(a) with dihedral angles $\alpha = \arccos(\frac{\sqrt{3}}{2\sqrt{2}})$ at “horizontal” edges and $\beta = \pi - 2\alpha$ at “vertical” edges. Note that \mathcal{P} is the unique such hyperbolic polyhedron with the dihedral angles as stated (see [20, 27]). In addition, let \mathcal{P}_n denote the ideal polyhedron obtained by “stacking” n copies of \mathcal{P} as shown in Fig. 5(b) (which shows \mathcal{P}_2).

Note that the dihedral angle at edges which arise from stacking copies of \mathcal{P} is 2α . The following is easy to deduce from Rivin’s characterization of convex ideal hyperbolic polyhedra [27].

Lemma 3.1. *Each \mathcal{P}_n is a convex ideal polyhedron.*

3.2. Arithmeticity of the links D_j and \mathcal{D}_j

As a first step towards proving Theorem 1.1, we establish that the complements of the links D_j and \mathcal{D}_j are hyperbolic, admitting decompositions into copies of \mathcal{P} .

Theorem 3.2. *For $j \geq 1$ the link complements $S^3 \setminus D_j$ and $S^3 \setminus \mathcal{D}_j$ admit decompositions into copies of \mathcal{P} with face pairings given by isometries of \mathbb{H}^3 .*

Proof. We discuss the case of D_j , and show that $S^3 \setminus D_j$ can be decomposed into two copies of the polyhedron \mathcal{P}_j ($j \geq 1$). The links \mathcal{D}_j can be handled in an analogous manner.

To begin we will follow the discussion of [9, Sec. 2.2], and consider an alternating diagram for D_j on some projection plane $S^2 \subset S^3$. This produces the 4-valent planar graph P_j (Fig. 6(a) shows P_2). Two-coloring the regions in checkerboard fashion

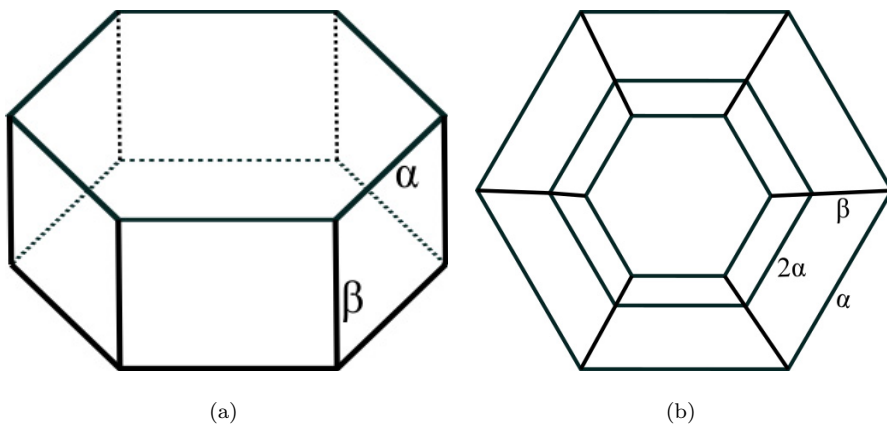

Fig. 5.

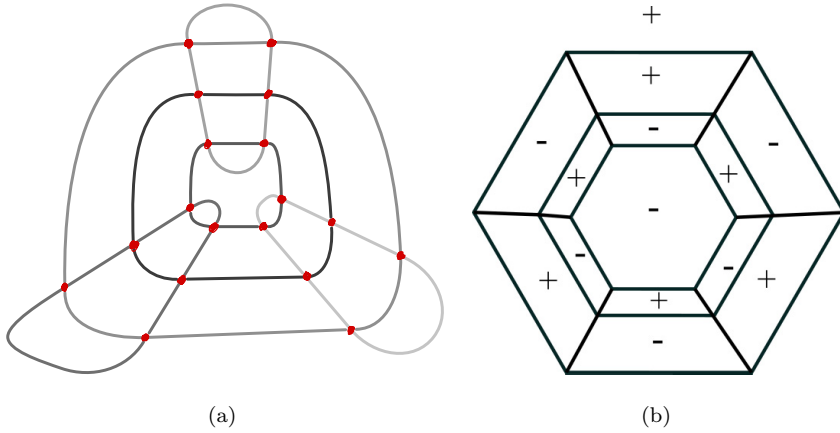

Fig. 6.

and labeling these regions as + and - determines a decomposition of S^3 into two 3-balls, each of which is endowed with an abstract polyhedral structure. Denote these polyhedra by Π_+^j and Π_-^j .

These polyhedra are identical up to reversing all the colors and signs. Each face f_i of Π_+^j is a n_i -gon (where $n_i = 2, 4$ or 6) with a sign $\sigma_i \in \{\pm\}$, and the polyhedra Π_+^j and Π_-^j are identified by sending f_i to the corresponding face of Π_-^j using a rotation of $\sigma_i 2\pi/n_i$ (with + denoting clockwise). The resulting complex with vertices deleted is then homeomorphic to $S^3 \setminus D_j$ (see [2, Theorem 2.1] for example).

Note that P_j contains 6 bigons, and we can collapse each of these bigons to an edge in each of the polyhedra Π_+^j and Π_-^j , and then make the identifications described above (see [2, Lemma 2.1] for example). We also note that these polyhedra now have vertices of degree three or four, but remain 2-colorable in the sense that any vertex of degree three does not have all incident faces having the same symbol + or - (see Fig. 6(b)).

The key point is that this combinatorial realization can be done geometrically: namely the identifications described above on Π_\pm^j can be realized as isometric identifications of two copies of \mathcal{P}_j (which, we recall, are built from j copies of \mathcal{P}). This can be done directly as we did in [9]; however, it can also be deduced from [2, Corollary 7.4] (stated below) as we now discuss.

Proposition 3.3. *Let P be a convex ideal hyperbolic polyhedron built up from simple polyhedra. Suppose that P only has vertices of degree three or four, and that P is 2-colorable. Then for any 2-coloring of P , the induced hyperbolic structure on the corresponding link complement is complete.*

We will not define the term *simple polyhedron* here and refer the reader to [2]. We simply remark that \mathcal{P} is simple, and moreover, in our case, each polyhedron \mathcal{P}_j

is convex (by Lemma 3.1), built from j copies of \mathcal{P} , with all vertices having degree three or four, and is 2-colorable. Applying Proposition 3.3, we obtain a complete hyperbolic structure on each of the link complements $S^3 \setminus D_j$ ($j \geq 1$). \square

The proof of Theorem 1.1 will be completed (i.e. the link complements are arithmetic and cover the orbifold $\mathbb{H}^3/\Gamma_{\mathcal{O}}$) by the following lemma.

Lemma 3.4. *The link complements $S^3 \setminus D_j$ and $S^3 \setminus \mathcal{D}_j$ are finite sheeted covers of $\mathbb{H}^3/\Gamma_{\mathcal{O}}$.*

Proof. From Theorem 3.2, we may conclude that the link complements $S^3 \setminus D_j$ and $S^3 \setminus \mathcal{D}_j$ can be decomposed into copies of \mathcal{P}). It remains to show that their fundamental groups are subgroups of $\Gamma_{\mathcal{O}}$ (up to conjugacy). We do this as follows.

The group of orientation-preserving isometries of \mathcal{P} is a dihedral group of order 12 and we can use this group action to subdivide \mathcal{P} into 12 copies of the polyhedron X shown in Fig. 7. Note that an integer n decorating an edge indicates an angle of $2\pi/n$ at that edge, and α and β are as in Sec. 3.1.

Furthermore, we fold the top and bottom faces of X along diagonals; fold the two front vertical faces along diagonals (to the cusp) and identify the two back vertical faces to each other by the order 6 rotation. Performing these identifications one can check that the resultant quotient orbifold is $Q_{\mathcal{O}}$ (as shown in Fig. 2(a)). In particular, we can conclude that these isometries generate $\Gamma_{\mathcal{O}}$.

Next, we describe how to realize $S^3 \setminus D_j$ and $S^3 \setminus \mathcal{D}_j$ by identifying two copies of \mathcal{P}_j as described in the first part of Theorem 3.2 using isometries contained in $\Gamma_{\mathcal{O}}$. This will establish that $S^3 \setminus D_j$ and $S^3 \setminus \mathcal{D}_j$ are arithmetic.

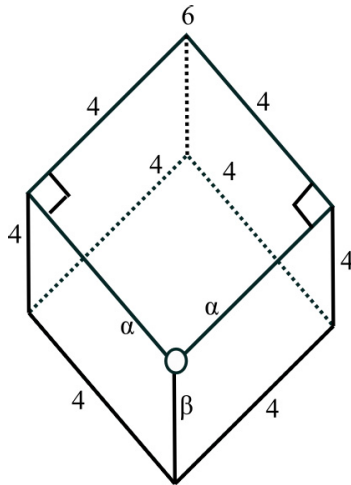

Fig. 7.

First identify \mathcal{P}_j^+ to \mathcal{P}_j^- along a pair of hexagonal faces to obtain a stack of $2j$ copies of \mathcal{P} . Now the remaining face identifications are made by products of elements of $\Gamma_{\mathcal{O}}$; i.e. rotations by $2n\pi/6$; translations along the central axis of the stack; rotations by π about diagonals in the faces of copies of \mathcal{P} .

To finish the proof we now show that $S^3 \setminus D_j$ and $S^3 \setminus \mathcal{D}_j$ are all finite sheeted covers of $\mathbb{H}^3 / \Gamma_{\mathcal{O}}^1$. To do this we will need to recall some terminology from [25].

Following [25], given an arithmetic Kleinian group Λ commensurable with $\mathrm{PSL}(2, O_{15})$ we set

$$\Lambda_{\mathbb{Q}(\sqrt{-15})} = \{\gamma \in \Lambda : \mathrm{tr}(\gamma) \in \mathbb{Q}(\sqrt{-15})\}.$$

From [25, Theorem 2.2(3)], $\Lambda_{\mathbb{Q}(\sqrt{-15})}$ is a finite index normal subgroup of Λ of index 2^a for some non-negative integer a . Consider the group $(\Gamma_{\mathcal{O}})_{\mathbb{Q}(\sqrt{-15})}$: this clearly contains the group $\Gamma_{\mathcal{O}}^1$, and we claim that $(\Gamma_{\mathcal{O}})_{\mathbb{Q}(\sqrt{-15})} = \Gamma_{\mathcal{O}}^1$. To see this, since $(\Gamma_{\mathcal{O}})_{\mathbb{Q}(\sqrt{-15})}$ is arithmetic, in fact, $\mathrm{tr}(\gamma) \in O_{15}$ for all $\gamma \in (\Gamma_{\mathcal{O}})_{\mathbb{Q}(\sqrt{-15})}$. From [22, Exercise 3.2(1)] we can form the order $\mathcal{O}(\Gamma_{\mathcal{O}})_{\mathbb{Q}(\sqrt{-15})}$ which must contain \mathcal{O} since $\Gamma_{\mathcal{O}}^1 \subset (\Gamma_{\mathcal{O}})_{\mathbb{Q}(\sqrt{-15})}$. However, \mathcal{O} is a maximal order and so $\mathcal{O}(\Gamma_{\mathcal{O}})_{\mathbb{Q}(\sqrt{-15})} = \mathcal{O}$. Hence, $(\Gamma_{\mathcal{O}})_{\mathbb{Q}(\sqrt{-15})} = \Gamma_{\mathcal{O}}^1$ as claimed.

We showed above that each of the link groups $\pi_1(S^3 \setminus D_j)$ and $\pi_1(S^3 \setminus \mathcal{D}_j)$ are subgroups of $\Gamma_{\mathcal{O}}$, and by [25, Corollary 2.3], $\pi_1(S^3 \setminus D_j)$ and $\pi_1(S^3 \setminus \mathcal{D}_j)$ are actually subgroups of $\Gamma_{\mathcal{O}, \mathbb{Q}(\sqrt{-15})}$, and hence subgroups of $\Gamma_{\mathcal{O}}^1$ by the previous paragraph. □

Remark 3.5. The same argument used to prove Lemma 3.4 also shows that $S^3 \setminus C_6$ is a finite sheeted cover of $\mathbb{H}^3 / \Gamma_{\mathcal{O}}^1$.

Remark 3.6. We have not checked whether any of the link complements $S^3 \setminus D_j$, $S^3 \setminus \mathcal{D}_j$ or $S^3 \setminus C_6$ also cover Q_{15} , however, we suspect that this is not the case.

4. Final Remarks

4.1. Non-arithmetic alternating link complements built from \mathcal{P}

In [9], we constructed two infinite families of alternating link complements commensurable with Q_3 , these were all *cubical*, in that they were built from regular ideal cubes. Indeed as proved in [9, Lemma 2.2], any cubical hyperbolic 3-manifold is arithmetic. One of the complications here is that a manifold built from copies of \mathcal{P} need not be arithmetic. Consider the alternating link shown in Fig. 8.

The complement of this link was built by arranging for the “upper” and “lower” polyhedra (which we denoted Π^+ and Π^- previously) to consist of two copies of \mathcal{P} stacked so that each hexagonal face shares an edge. To the extent of rigor that Snap [11] permits, this manifold has trace-field $\mathbb{Q}(\sqrt{-15})$ but is not arithmetic since there is an element whose trace is not an algebraic integer.

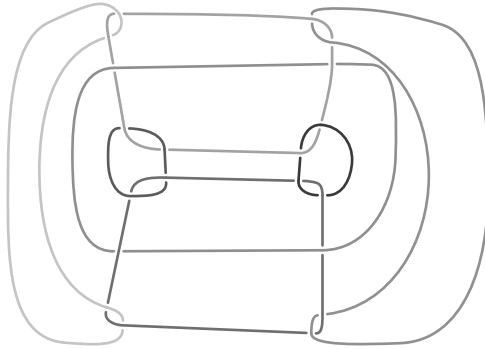

Fig. 8.

4.2. Closed embedded essential surfaces

As in [9], most of the link complements $S^3 \setminus D_j$ and $S^3 \setminus \mathcal{D}_j$ can be shown to contain closed embedded essential surfaces. In particular, the argument of [9, Sec. 4] proves.

Theorem 4.1. *For each $j > 2$ (respectively, $j > 1$) the link complements $S^3 \setminus D_j$ (respectively, $S^3 \setminus \mathcal{D}_j$) contain a closed embedded essential surface.*

4.3. Describing all arithmetic alternating link complements

We finish by raising the challenge problem of describing *all* arithmetic alternating link complements. The results of [9] and this note exhibit several infinite families of arithmetic alternating links: namely L_j, \mathcal{L}_j (from [9] for which the link complements cover Q_3), D_j and \mathcal{D}_j for $j \geq 1$ (for which the link complements are commensurable with Q_{15}). Given Hatcher's examples in [18] when $d = 1, 2, 3, 7, 11$, a natural question is therefore:

Question 1. For $d = 1, 2, 7, 11$, are there any infinite families of arithmetic alternating links?

If Question 1 has a negative answer, what are the remaining finitely many arithmetic alternating links? Using a variation of the techniques in [18] (and those here), we have produced other examples of arithmetic alternating links when $d = 7, 11$, and these are shown in Figs. 9(a) and 9(b), respectively. Note that, using SnapPy [12], the complement of the link in Fig. 9(a) can be seen to be isometric to the complement of the non-alternating link in [17] with fundamental group $\Gamma_{-7}(12, 17)$ (in the notation of [17]).

Question 2. Are there any more?

In the case when $d = 1$, the referee pointed out that, in addition to the Whitehead link and the Borromean rings, the 10 crossing two component alternating link

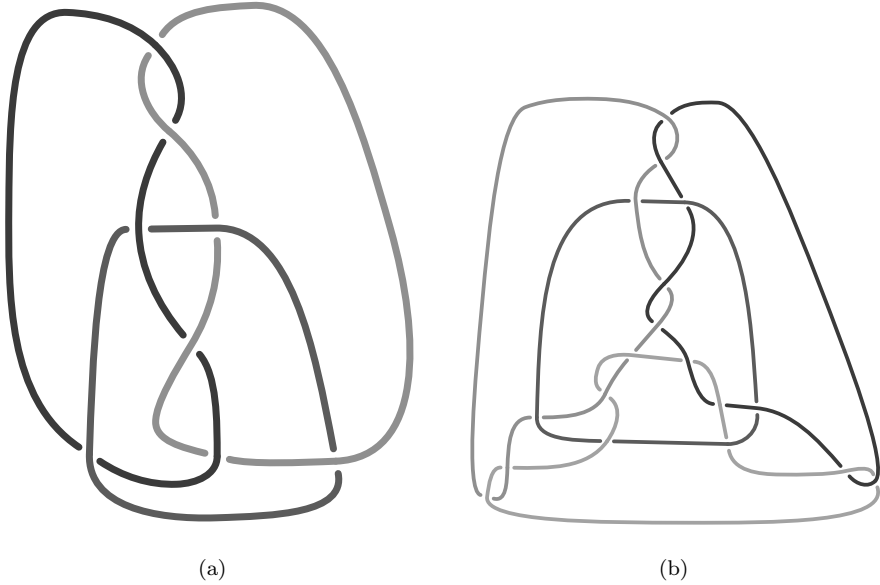

Fig. 9.

L10a119 of the Thistlethwaite Link Table [30] has a complement that decomposes into three right angled octahedra, and so covers Q_1 (of covering degree 36). On the other hand, we checked that the decomposition of this link complement obtained à la Menasco [23] (i.e. by the procedure described in Sec. 3.2) does **not** give a decomposition into octahedra; the polyhedra in question have 2 hexagonal faces and 4 quadrilateral faces (this phenomena was pointed out in [2]).

Moreover, any link complement covering Q_1 admits a decomposition as a union of right angled octahedra, and we note that if the polyhedra produced by the method described in Sec. 3.1 were known to be *completely realizable by ideal hyperbolic right angled polyhedra* (in the sense of [13]), then by [13] this would identify the link as the Borromean rings.

In connection with this, the referee also pointed out that the `Octahedral OrientableCuspedCensus` of SnapPy [12] which consists of the census of manifolds in SnapPy that are made up of 7 or fewer regular ideal octahedra, contains 11,272 manifolds but has not been properly searched to identify link complements, alternating or otherwise. Such a search now seems possible.

Additionally, we recently noticed that in the tables of [16] the manifold `m203` of the SnapPy census [12] was identified as arithmetic, covering Q_3 (of covering degree 24). This manifold is homeomorphic to the complement in S^3 of the link 6_2^2 of Rolfsen's tables [26].

Finally, for the sets C and C' as defined in Sec. 1, are there other values of $d \in C \cup C'$, for which there exists an arithmetic alternating link?

Acknowledgments

Both authors thank the Max-Planck-Institut für Mathematik, Bonn, for its hospitality during the preparation of this work. We are also very grateful to Tam Cheetham-West for his help in drawing some of the figures, and to the referee for helpful comments and in particular pointing out the arithmetic alternating link discussed in Sec. 4.3.

Reid was supported in part by a NSF grant and by the Max-Planck-Institut für Mathematik.

ORCID

M. D. Baker  <https://orcid.org/0009-0000-1762-5785>

A. W. Reid  <https://orcid.org/0000-0003-0367-9453>

References

- [1] I. R. Aitchison, E. Lumsden and J. H. Rubinstein, Cusp structures of alternating links, *Invent. Math.* **109** (1992) 473–494.
- [2] I. R. Aitchison and L. D. Reeves, On Archimedean link complements, *J. Knot Theory Ramifications* **11** (2002) 833–868.
- [3] I. R. Aitchison and J. H. Rubinstein, Combinatorial cubings, cusps, and the dodecahedral knots, in *Topology '90*, Ohio State University Mathematical Research Institute Publications, Vol. 1 (de Gruyter, 1992), pp. 55–59.
- [4] M. D. Baker, Link complements and quadratic imaginary number fields, Ph.D. thesis, M.I.T. (1981).
- [5] M. D. Baker, Link complements and integer rings of class number greater than one, in *Topology '90*, Ohio State University Mathematical Research Institute Publications, Vol. 1 (de Gruyter, 1992), pp. 55–59.
- [6] M. D. Baker, Link complements and the Bianchi modular groups, *Trans. Amer. Math. Soc.* **353** (2001) 3229–3246.
- [7] M. D. Baker, Commensurability classes of arithmetic link complements, *J. Knot Theory Ramifications* **10** (2001) 943–957.
- [8] M. D. Baker, M. Goerner and A. W. Reid, All known principal congruence links, preprint (2019), arXiv:1902.04426.
- [9] M. D. Baker and A. W. Reid, Infinitely many arithmetic alternating links, *Algebr. Geom. Topol.* **23** (2023) 2857–2866.
- [10] J. Blume-Nienhaus, Lefschetz numbers für galois-operationen auf der kohomologie arithmetischer gruppen, Ph.D. thesis, Universität Bonn (1991).
- [11] D. Coulson, O. A. Goodman, C. D. Hodgson and W. D. Neumann, Computing arithmetic invariants of 3-manifolds, *Exp. Math.* **9** (2000) 127–152.
- [12] M. Culler, N. M. Dunfield, M. Goerner, and J. R. Weeks, SnapPy, a computer program for studying the geometry and topology of 3-manifolds, version 2.6 (2017), <http://snappy.computop.org>.
- [13] H-C. Gan, Alternating links with totally geodesic checkerboard surfaces, *Algebr. Geom. Topol.* **21** (2021) 3107–3122.
- [14] M. Goerner, Visualizing regular tessellations: Principal congruence links and equivariant morphisms from surfaces to 3-manifold, Ph.D. thesis, U. C. Berkeley (2011).

- [15] M. Goerner, A census of hyperbolic platonic manifolds and augmented knotted trivalent graphs, *New York J. Math.* **23** (2017) 527–553.
- [16] O. Goodman, D. Heard and C. D. Hodgson, Commensurators of cusped hyperbolic manifolds, *Exp. Math.* **17** (2008) 283–306.
- [17] F. Grunewald and U. Hirsch, Link complements arising from arithmetic group actions, *Int. J. Math.* **6** (1995) 337–370.
- [18] A. Hatcher, Hyperbolic structures of arithmetic type on some link complements, *J. Lond. Math. Soc.* **27** (1983) 345–355.
- [19] A. Hatcher, Bianchi orbifolds of small discriminant, preprint (1983), available at <https://pi.math.cornell.edu/~hatcher/Papers/Bianchi.pdf>.
- [20] C. D. Hodgson, I. Rivin, and W. D. Smith, A characterization of convex hyperbolic polyhedra and of convex polyhedra inscribed in the sphere, *Bull. Amer. Math. Soc.* **27** (1992) 246–251.
- [21] M. Lackenby, Spectral geometry, link complements and surgery diagrams, *Geom. Dedicata* **147** (2010) 191–206.
- [22] C. Maclachlan and A. W. Reid, *The Arithmetic of Hyperbolic 3-Manifolds*, Graduate Texts in Mathematics, Vol. 219 (Springer-Verlag, 2003).
- [23] W. W. Menasco, Polyhedra representation of link complements, in *Low-Dimensional Topology (San Francisco CA, 1981)*, Contemporary Mathematics, Vol. 20 (American Mathematical Society, 1983), pp. 305–325.
- [24] W. W. Menasco, Closed incompressible surfaces in alternating knot and link complements, *Topology* **23** (1984) 37–44.
- [25] W. D. Neumann and A. W. Reid, Arithmetic of hyperbolic manifolds, in *Topology '90*, Ohio State University Mathematical Research Institute Publications, Vol. 1 (de Gruyter, 1992), pp. 273–310.
- [26] D. Rolfsen, *Knots and Links* (Publish or Perish, 1976).
- [27] I. Rivin, A characterization of ideal polyhedra in hyperbolic 3-space, *Ann. Math.* **143** (1996) 51–70.
- [28] J. Stephan, Construction d'entrelacs hyperpoliques et arithmétiques, *C. R. Acad. Sci. Paris Sér. I Math.* **324** (1997) 543–547.
- [29] J. Stephan, On arithmetic hyperbolic links, *J. Knot Theory Ramifications* **8** (1999) 373–389.
- [30] The Thistlethwaite Link Table, available at http://katlas.math.toronto.edu/wiki/The_Thistlethwaite_Link_Table.
- [31] W. P. Thurston, *The Geometry and Topology of 3-Manifolds*, Princeton University mimeographed notes (American Mathematical Society, 1979).
- [32] K. Vogtmann, Rational homology of Bianchi groups, *Math. Ann.* **272** (1985) 399–419.